

## ■ 先导头简图

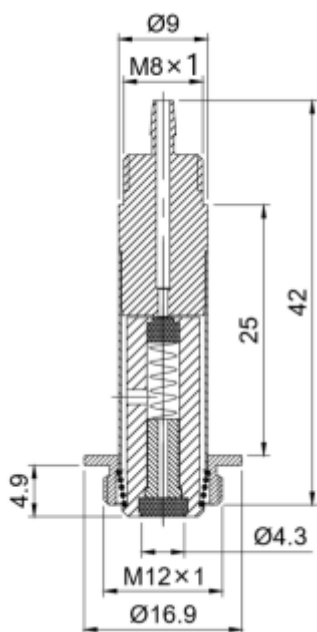

## 产品参数清单

### ALT 037-10

套管外径 × 高度	接口尺寸	二通 / 三通	常闭 / 常开	密封件尺寸	交流 / 直流	隔磁管材质	配合线圈型号
Φ9×25	M12×1	三通	常闭	Φ4.3	直流	不锈钢	ALTC 079

## ■ 产品说明

1. 静铁芯采用高导磁、低剩磁、防锈、耐腐蚀材料制作，经久耐用、反应灵敏。
2. 隔磁管采用管壁厚度 0.25mm 的 304 不锈钢无缝钢管制作，防锈、防裂、耐磨、耐腐蚀。
3. 采用激光焊接技术，使产品连接更紧密、牢固、耐用。
4. 弹簧材料采用进口不锈钢弹簧专用钢丝制作，压力稳定，复原性能良好。
5. 密封材料采用耐化学药品、耐水、耐天候老化、耐臭氧的 EPDM 材料制作，密封件使用温度 -50°C ~ 100°C。

■ **线圈外观图**

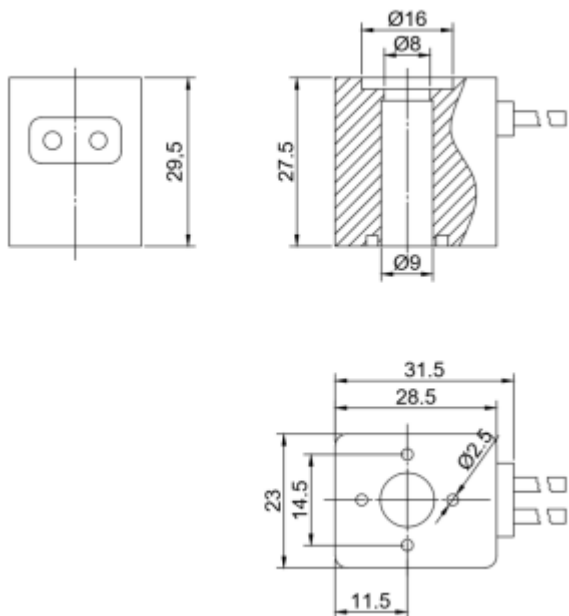

■ **线圈参数表**

常规电压	AC220V AC110V DC24V DC12V		
常规功率	AC	4VA 5.5VA 6VA 8.5VA	
	DC	3W 4.8W 6W 8W	
其他特种电压、特种功率可定制			
绝缘等级	B、F		
线圈连接方式	引线式		

## Brief Drawing

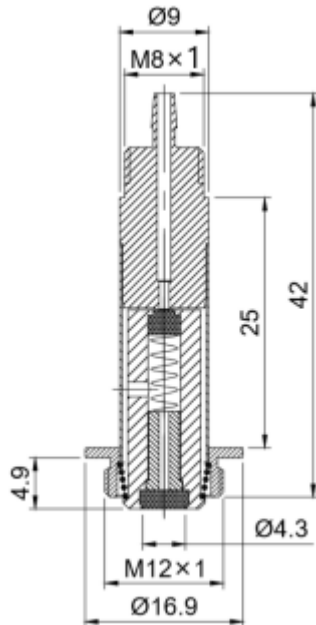

## Product Parameters

ALT037-10							
Tube Assy OD×H	Connection Size / Thread Size	2Way/3Way	NO/NC	Seal Pad Size	AC/DC	Tube Assy Material	Coil For Option
Φ9×25	M12×1	3Way	NC	Φ4.3	DC	Stainless Steel	ALTC079

## Description

1. Static core and movable plunger are made of materials which has high magnetic permeability, low magnetic residual and excellent anti-corrosion and rust resistance, All of the features make the products durable and responsive.
2. By applying 0.25mm ,SUS304 seamless tube, products have excellent features of durability, anti-corrosion as well as rust resistance.
3. Laser welding technology makes seal condition much safer than normal clamp process.
4. Imported stainless steel spring wires makes stable force and good resilience.
5. Seal material is made of excellent EPDM,, temperature ranges from -50° -100° .

**Brief drawing**

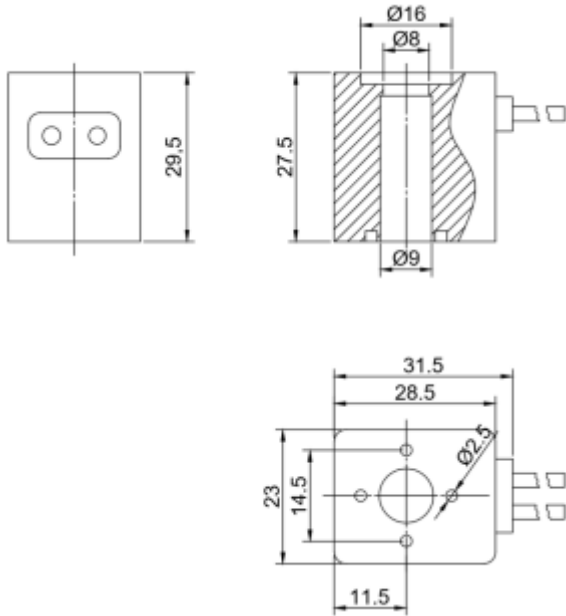

**Product Parameters**

Normal Voltage	AC220V AC110V DC24V DC12V		
Normal Power	AC	4VA 5.5VA 6VA 8.5VA	
	DC	3W 4.8W 6W 8W	
Other voltage and power can be customized			
Insulation Class	B、 F		
Connection Type	With Flying Leads		